

## Continuous Product Improvements

news

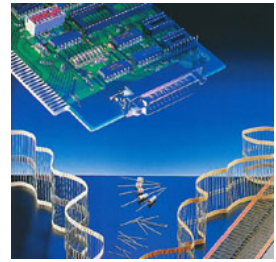

This paper was presented at the CARTS-Europe `98 symposium in Huntington Beach, USA

### **REDUCTION OF LEAD-CONTENT IN LEAD-WIRE-COATINGS - TECHNICAL IMPACTS AND APPLICATION-EXPERIENCES -**

**Gerhard Bürstner (Dipl.-Ing. Dipl. Wirtsch. Ing. )**

**Eckhard Fröhlich (Dipl. Ing.)**

Feindrahtwerk Adolf Edelhoff GmbH & Co.  
Am Großen Teich 33  
D-58640 Iserlohn, Germany  
Phone: +49 2371 438034  
Fax \*49 2371 40097  
E-mail: [edelhoff@edelhoff-wire.de](mailto:edelhoff@edelhoff-wire.de)

## **1. SUMMARY**

The reduction of lead-content became a major topic for the design and the production of passive components, independently, whether they are leaded or SMDs.

Multinational companies started to create safety regulations, where end-products, which contains lead, has to be registered and accepted by special procedures. Other companies announced the use of totally lead-free alloys in their production . Therefore the tendency to avoid lead at all will increase.

In this paper specific attention is given to:

- various coating technologies
- single layer and multi layer coatings
- impact of lead reduction and tin enrichment
- impacts during the production process of passive components

Recommendations are given in regard to:

- coating - technology and
- production - parameters
- step-wise lead-reduction

All these informations support producers of passive components, who have to change their present

product specification, and/or their existing production process.

Mile stones for getting a lead-reduced or even a lead-free component can be found.

## **2. INTRODUCTION**

Lead and lead-compounds belong to a group of environmental- and health-endangering materials. Their disadvantages are:

- Toxicity. Lead damages the central nervous system and causes anemia, cancer etc..
- Lead can penetrate into the ground water, if lead-contaminated electronic scrap is stored on disposal sites.
- Lead requires an expensive recycling procedure.

The desired reduction of lead is based on two factors:

- Protection of the environment against contamination with critical materials
- to put a stronger focus on safety regulations for workers, who are handling those materials, which might cause health problems.
- cost-saving recycling procedures

Multinational companies started to create safety regulations, where end-products, which contain lead, has to be registered and to be accepted by special procedures. In addition to that there are already existing standards, e.g. 91/155/EWG, where special sheets inform about properties and special effects of critical products and where recommendations for their handling are given.

Nevertheless the annual Pb-production is nearly up to 3,8 million tons. The main applications for the use of lead (more than 60%) are in the production process of batteries; 7% of the total consumption of lead is being used in the electronic industry [1].

It can be said in general: the tendency to avoid lead at all will increase.

## **3. REASONS FOR USING LEAD**

Before starting to discuss topics in regard to the reduction of lead in lead wires, the main commercial and technical and reasons for the use of lead should be noted:

Lead is used as an additive to tin-solder, as it

- is cheaper than tin.
- has a rather low melting temperatur itself (327°C).
- enables to lower the melting temperature of Sn/Pb alloys down to 183°C, which reduces the temperature impact on passive components during their assembling process.
- leads to easy and reliable soldering, as significant experience is available
- has in general favourable mechanical, thermal and electrical properties
  - high density, electrical and thermal conductivity, flexibility
  - low hardness, abrasion strength and elastic modulus
- prevents whisker formations

## 4. Coating Metals

General requirements for lead wires being used for the production of passive components are:

- excellent solderability
- high surface quality
- low diameter tolerance
- high ductility of the coating
- good aging resistance
- defined properties, such as electrical and thermal conductivity, tensile strength and elongation

Standard coating metals are:

- Tin/Lead coating (Sn/Pb 95/5, 60/40, 30/70)
- Pure tin coating (Sn)
- Copper coating
- Nickel coating

Core materials for common lead wires are: copper, copper alloys, nickel, nickel alloys, steel, steel alloys, steel copper. Specialties are: brass, bronze, nickel-silver.

## 5. COATING METHODS

### 5.1. The Electroplating Process

As already presented in previous CARTS papers [2] [3] the wire passes pretreatment baths and cleaning baths, and is then coated in several added steps.

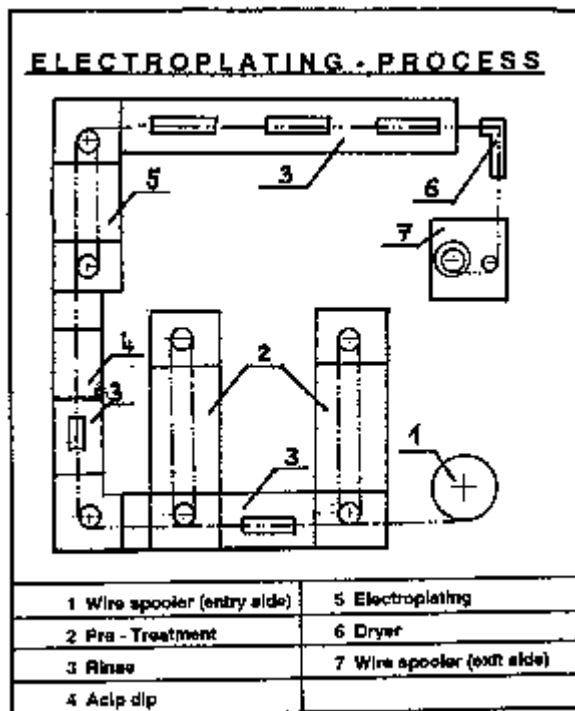

Fig. 1 The Electroplating Process

### 5.2. The Concentric Hot-Dip Tinning Process FOV

EDELHOFF developed the concentric hot-dip tinning process FOV more than 10 years ago according to specific customer requirements. The basic for this FOV- development was the common known hot-dip tinning coating, which usually creates non-concentric coatings.

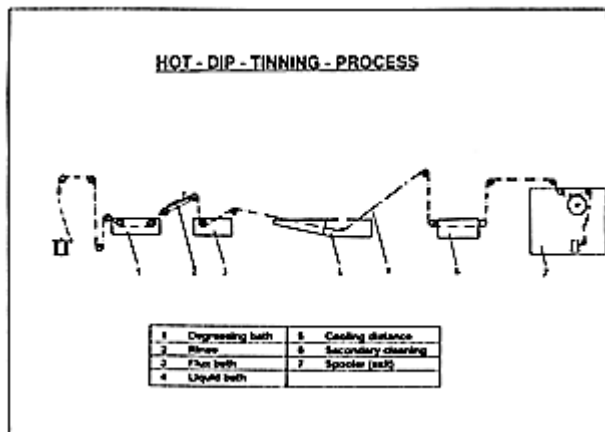

Fig. 2 The Hot-Dip Tinning Process

The wire passes several cleaning baths and a specific bath with flux [2] [3]. Then the wire gets its surface-coating by being solder-dipped in molten tin/lead or pure tin. After cooling and cleaning the coated wire is recoiled again. A special system provides a concentric tin-coating on the wire.

### 5.3. Single and Double Coating

The EDELHOFF coating process is capable not only for single layer coatings, but also for double or multi layer coatings.

Some special applications require to have double coatings. Examples for such combinations are:

- Steel wire:                    Ni + Sn (Sn/Pb)
  
- Brass wire:                    Ni + Sn (Sn/Pb)
  
- Bronze wire:                    Ni + Sn (Sn/Pb)  
    or Cu + Sn (Sn/Pb)
  
- Copper wire:                    Sn/Pb 30/70 + Sn/Pb 95/5  
    or Sn/Pb 30/70 + Sn  
    or Ni + Sn (Sn/Pb)

### 5.4. Combined Methods

EDELHOFF is producing according to both coating methods

- the electroplating process and
- the hot-dip tinning process

For special applications the advantages of both coating methods are combined, as a multi layer coating - possibly by using two different coating-technologies -is produced.

## 6. LEAD - REDUCED AND LEAD - FREE SURFACE COATINGS

### 6.1. Lead-Free Alloys

Some new alloys have been presented at the CARTS 1996 in Nice/France as possible future coatings [4], [5], which avoid lead:

- Tin-Bismuth-Alloys (Sn/Bi)
- Tin-Indium-Alloys (Sn/In)

Present publications show [6] that specific attention in Europe and the US is given to this topic.

Advantages from those new alloys will strongly come up, if all parts within an electronic printed circuit board will be based on those new alloys.

### Solder connection at components

with tin - bismuth (Sn - Bi)

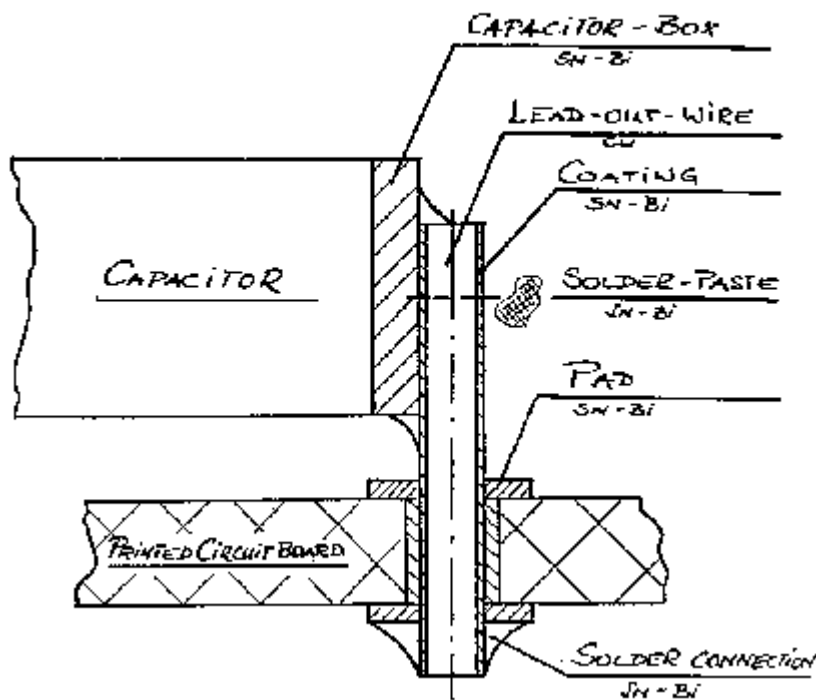

Fig. 3 Solder Connection at Components

### 6.2. Steps for Lead-Reduction

To avoid lead at all within the production process of an electronic component tends to be a long lasting process, till all manufacturers redesigned their products, restructured their production processes and got sufficient reliability experiences.

EDELHOFF supports these new technologie but gives in the meantime in addition to that assistance in avoiding or at least reducing lead as far as lead wires with conventional tin/lead alloys are concerned.

EDELHOFF's recommendation is:

The first approach is to reduce the lead content in tin-lead alloys, the second approach is to use pure tin coatings without any lead at all. By reviewing present processes, possibilities for rationalization can be found.

The reduction of lead can be achieved by reducing the lead content in a single layer tin/lead alloy coating or by using a double layer coating with less lead in the the second layer. An example for such a double layer coating should be given:

Underlayer - Hot-Dipped Quality (FOV):

Sn/Pb 30/70 or Sn/Pb 60/40

- intermetallic bond of the FOV- quality
- excellent solderability
- superior ductility

Coverlayer - Electroplated Quality (GDV):

Sn/Pb 95/5

- Solderability 100 %
- The reduced lead content of 5 % causes a harder surface and a higher abrasion resistance

Due to special customer requirements other combi-nations are used as well.

### 6.3. Consequences of Lead Reduction and Tin Enrichment

The reduction of lead in the tin-coating leads to a tin enrichment. The change of the lead-content has various impacts on special properties, such as:

- melting temperature
- surface hardness
- abrasion strength
- solderability
- whisker prevention

#### 6.3.1. The Melting Temperature

The melting temperature differs according to the percentage of the lead-content within the tin/lead alloy. Specific attention should be given also to Raynor and his tin-lead diagram [7].

The melting temperatures are:

Pb	- 327 °C
Sn/Pb 30/70	- 270 °C
Sn/Pb 60/40	- 190 °C
Sn/Pb 95/5	- 220 °C
Sn	- 232 °C

- As far as presently used wave or reflow soldering process uses a temperature of 235°C, lead-reduced coatings Sn/Pb 60/40 or Sn/Pb 95/5 can be used from the meltingpoint view.

#### 6.3.2. The Surface Hardness

The surface hardness is a significant factor within the production process of the component itself, as

the lead wires will be transported with mechanical fingers to the body of the electronic component. Wires with higher surface hardness can be handled more easily from the mechanical point of view. Machine speed-ups, which might be possible, can rationalize the production process.

In general: Tin has a higher hardness than lead. EDELHOFF examined already the surface hardness of lead wires with different coating materials [3]. Further investigations were taken.

Fig. 4 shows the Vickers-hardness for a copper wire with 0.80 mm diameter, depending on the tin coating. The used coatings are pure tin (Sn), Sn/Pb 95/5 (L5), Sn/Pb 60/40 (L40) and Sn/Pb 30/70 (L70).

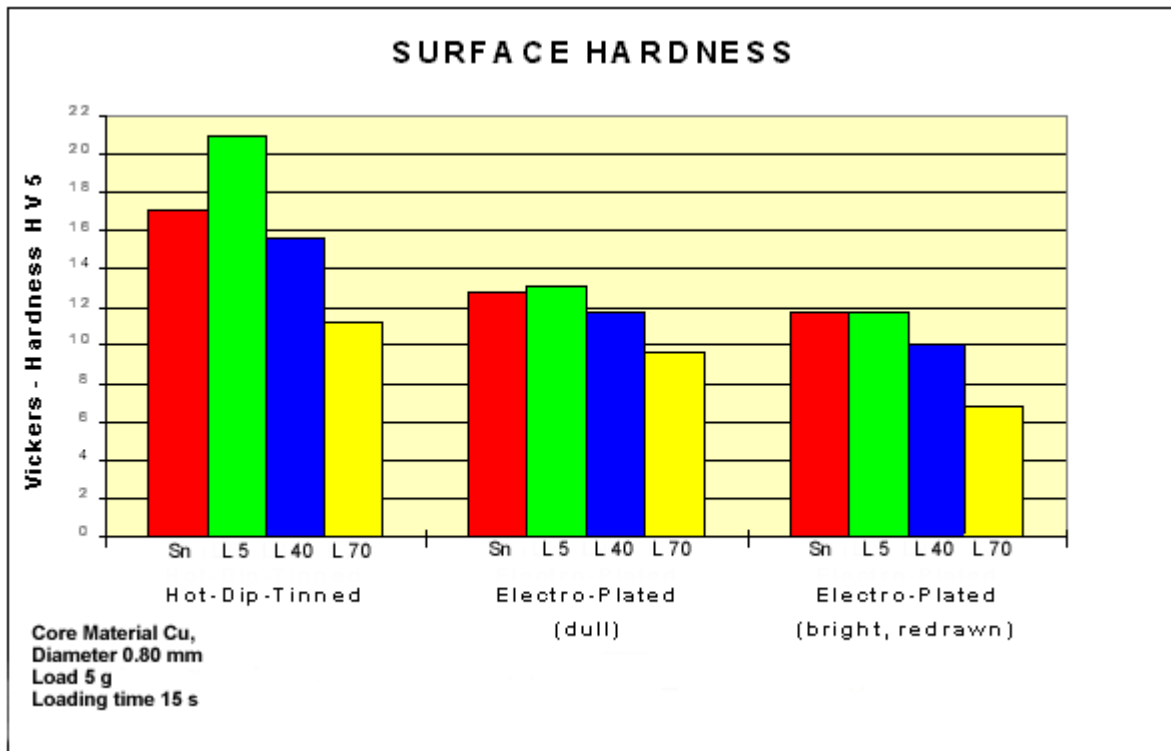

Fig. 4 Surface Hardness of Coated Wires

- Lead reduction will improve the surface hardness.
- Hot-dip tinned products have a higher surface hardness compared to equivalent electroplated versions.
- The higher end of surface hardness is given by FOV coatings with 5% lead content or even with pure tin.

### 6.3.3. Abrasion Strength

EDELHOFF made comparative tests for getting indications for abrasion strengths [3]. 14 different pencils with increasing grades of hardness (4B - 8H) are placed on and moved along the lead wire surface. That pencil with it's defined hardness defines the abrasion strength, which peels the tin coating for the first time.

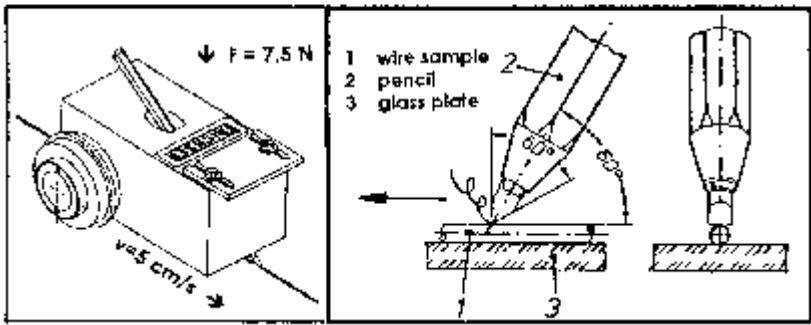

Fig. 5 Measuring Instrument for Abrasion Strength

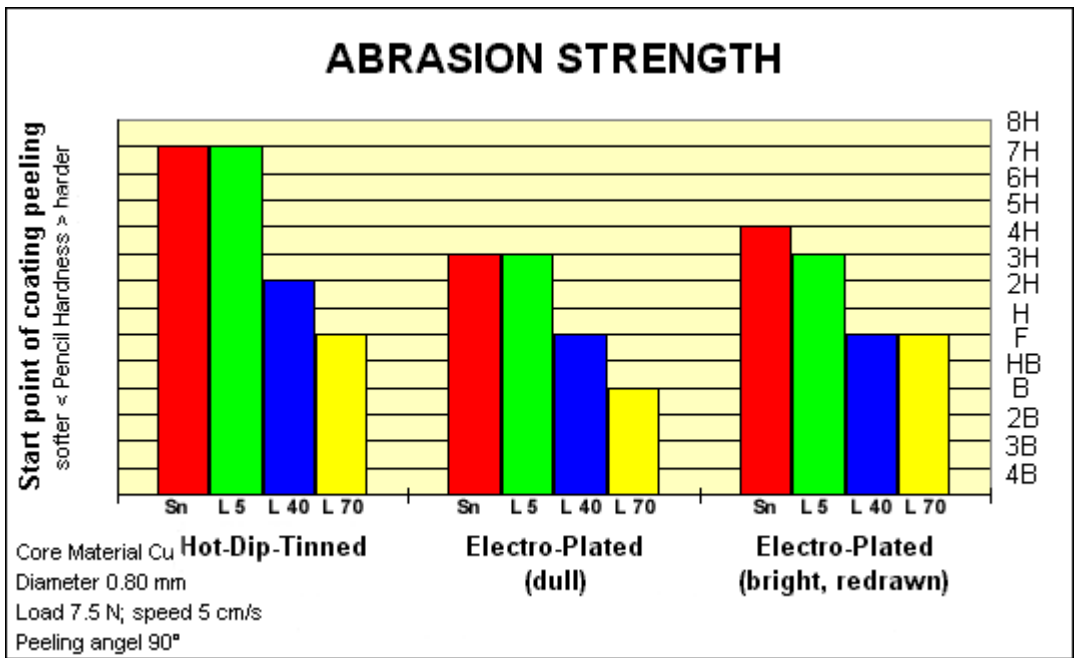

Fig. 6 Abrasion Strength of Coated Wires

- Lead reduction will also improve the abrasion strength.
- Hot-dip tinned products have a higher abrasion strength compared to equivalent electroplated versions.
- The higher end of abrasion strength is given by FOV coatings with 5% lead content or even with pure tin.

#### 6.3.4. Solderability

Good solderability is an essential requirement for lead wires. EDELHOFF examined the influence of the lead reduction in the tin/lead coating on the solderability [3]. Further investigations were taken.

The solderability was tested by the wetting balance method according to DIN IEC 68 part 2 - 54.

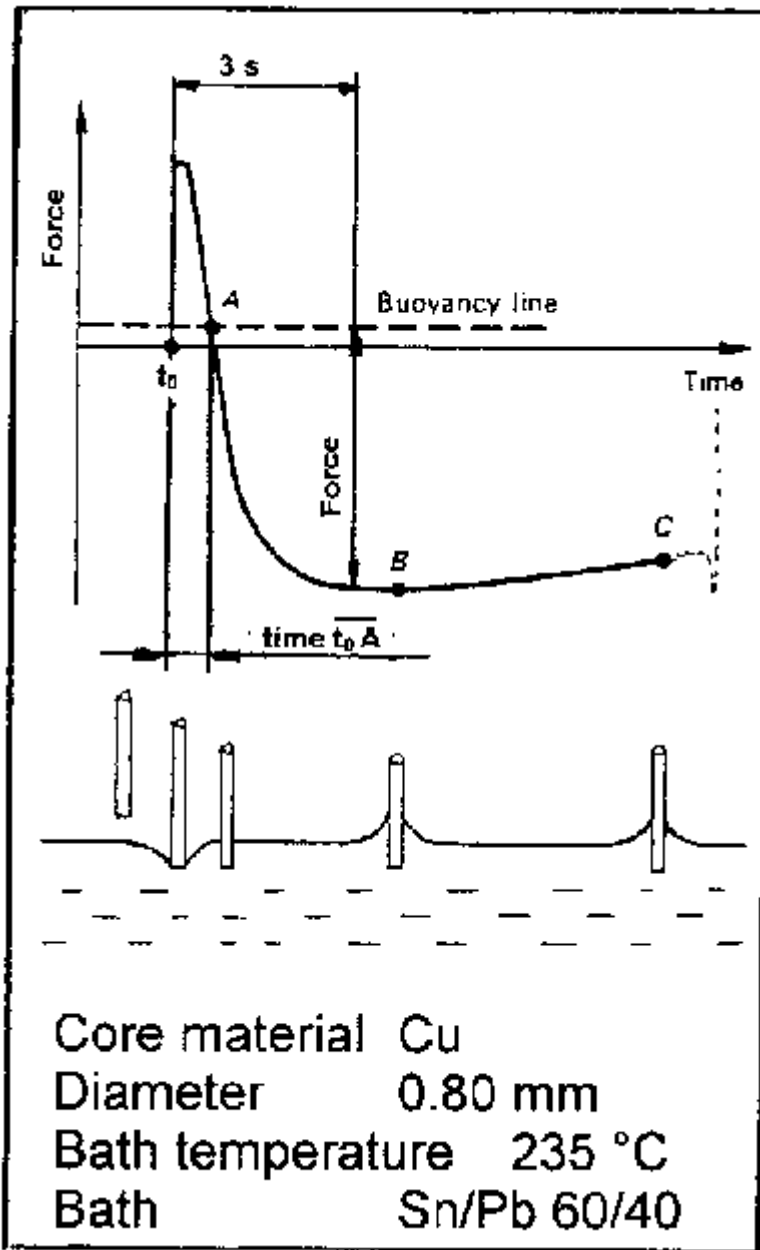

Fig. 7 Solderability Test by the Wetting Balance Method

6.3.4.1. Solderability - The Wetting Time

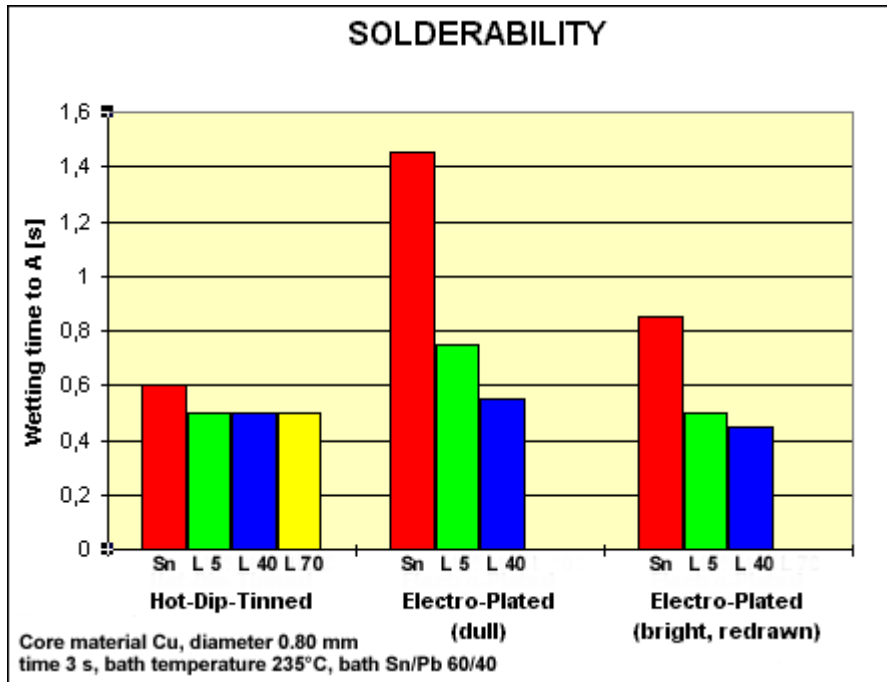

Fig. 8 The Wetting Time of Coated Wires

The wetting time should not be longer than 1s - 2,5s according to DIN IEC 68 - part 2 - 54.

- Increasing Pb-contents lead to shorter wetting times.
- Hot-dip tinned products ensure shorter wetting time than electroplated products.
- Electroplated-dull wires need a longer wetting time than electroplated-bright wires.
- The FOV coating with pure tin (Sn) has only a insignificantly higher wetting time compared to the FOV Sn/Pb 95/5 (L5) coating.

#### 6.3.4.2. Solderability - The Wetting Force

High wetting force is an indication for a good solderability.

Fig. 9 shows the comparative test results:

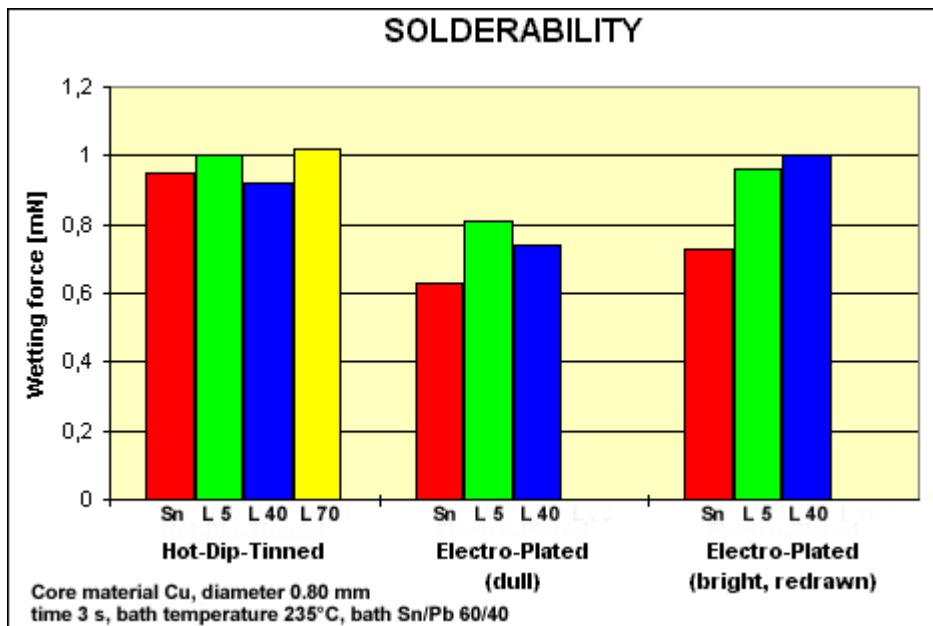

Fig. 9 Wetting Force of Coated Wires

- The variation of the lead-content doesn't change the wetting force significantly. That means, lead can be reduced without getting poorer results from the wetting-force-standpoint.
- Electroplated coatings with bright surface show a higher wetting force than equivalent electroplated versions with dull surface.
- For pure tin (Sn), the hot-dip tinning process FOV leads to the highest wetting force.

#### 6.3.5. Prevention of Whisker Formation

Whiskers are fine, capillary single crystals consisting of different materials, which may grow out of the metallic layer. Whiskers have a diameter of 1 to 2  $\mu\text{m}$  and can reach a length of about 3 mm [8].

- Whiskers might cause failures by forming short-circuits.

Although the exact mechanism of whisker growth isn't yet understood in detail, tin-whiskers may occur only in electroplated pure tin coatings. Stress in the plating is probably the most important factor leading to whisker growth [9].



Fig. 10 Scanning Electron Micrograph (SEM) concerning a whisker growth out of an electroplated tin layer [9]

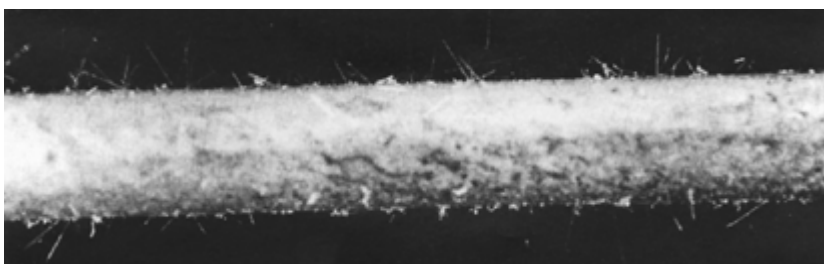

Fig. 11 Whiskers on a Coated Wire [9]

- No whisker-formation at all by using the hot-dip tinning process FOV with pure tin, as the coating comes directly from the molten bath.
- No whisker-formation by using electroplated coatings, if there is a lead-content of min. 2% [9].

No whisker-formation by using electroplated coatings, if the coating is heated above its melting temperature [9].

## **7. CONCLUSIONS**

The above mentioned investigations leads to a number of important statements:

### Lead-Reduction and Lead-Elemination

- There are existing possibilities to reduce or avoid lead at all - even by using the present process.
- Producers of passive components and PCBs could use a step-programm to abandon lead.
- In a first step a lead-reduction could take place.
- A second step for certain products would lead to totally lead-free products.
- Some producers of passive components, such as Beyschlag, Philips/Germany, went this way since many years.
- In a third step new alloys without lead could be approved.
- Depending on the presently used coating process there are different alternatives and chances for rationalization.

### Electroplating Process

- Pb can be reduced down to 2 - 5 % (Sn/Pb 95/5). The impacts concerning wetting-time has to be taken into consideration. Bright surfaces leads to shorter wetting-times.
- Pb-reduction down to zero (Sn 100 %) is possible, but only with an additional process. The pure tin coating must be heated up above it's melting temperature.

### Hot-Dip Tinning Process FOV

- Pb-reduction down to zero (Sn 100 %) is possible without any additional steps. There is no whisker formation as the coating comes directly from a molten bath. In addition to that there are advantages concerning increased hardness, abrasion strength and wetting force. The wetting time becomes shorter.

### Pure Tin Coatings (Sn 100%)

- As far as used PCB-soldering systems run with bath temperatures of 235°C or more, lead-free-coated wires or wires with lead-reduced coatings Sn/Pb 95/5 can be used as well.

## **REFERENCES**

[1] Salisbury, I.: Lead Free Solder Connections in Electronic Assemblies ,in CARTS-EUROPE `96, Seminar 2, p.1.0.

[2] Bürstner,G. and Fröhlich, E., The Hot-Dipped Tinning Process For Lead-Free Electrical Connections; in CARTS-USA `97, pp. 174.

[3] Bürstner,G. and Fröhlich, E., Electroplating versus Hot-Dipped Tinning - A Comparison of Application-Experiences, in CARTS-EUROPE `97, pp 17.

[4] Jordan, Dr. Manfred: Plating Technology. in CARTS-EUROPE `96, Seminar 2, pp.2.1.

[5] Dowds, Steve: Pb-Free Alloy Development, in CARTS-EUROPE `96, Seminar 2, pp. 3.1.

[6] Miric, Anton Zoran and Grusd, Angela: Bleifreie Lotlegierungen, in: Productronic 11/97, pp. 34 - 43.

[7] Raynor, G.V., Inst. Metals Annotated Equilibrium Diagram Series, No. 6, 1947.

[8] Jordan, Dr. Manfred: Die galvanische Abscheidung von Zinn und Zinnlegierungen, LEUZE-Verlag,

1993, p.183.

[9] Tin Whisker Growth in Telecommunication Equipment, in Bellcore Report SR-3151.